

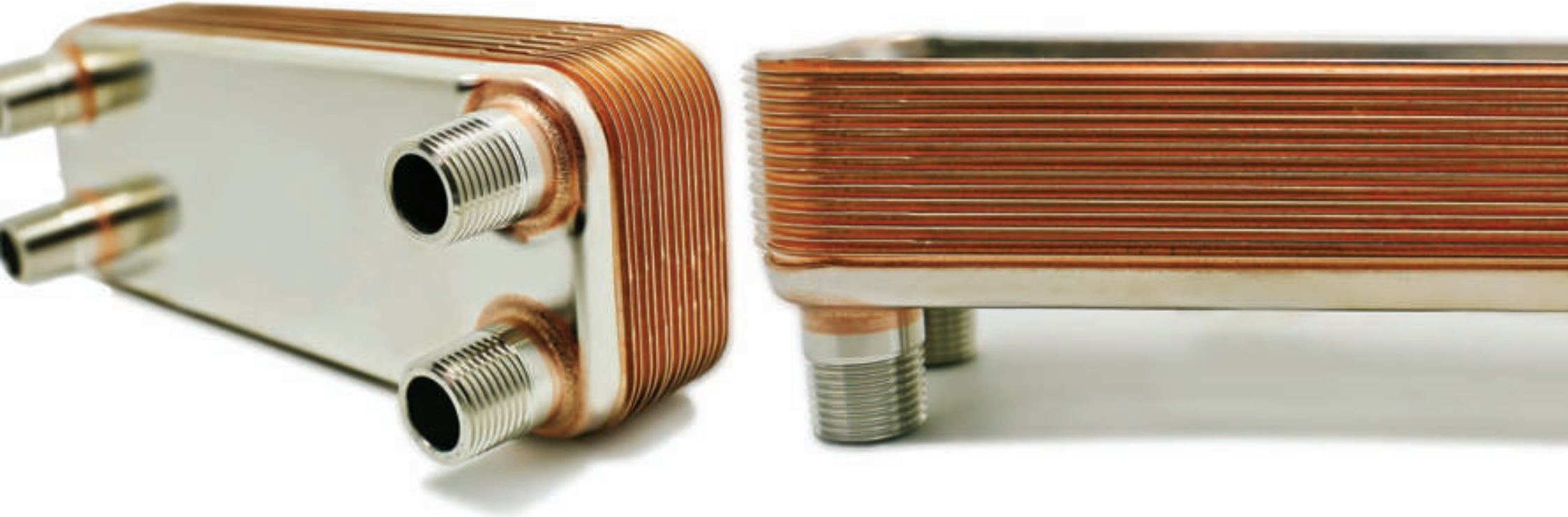

-Brazed plate heat exchanger

- Gasket plate heat exchanger

Brazed Plate Heat Exchanger





Construction of Brazed PHE



Brazed PHE Material	
Channel plates :	316L or 304 stainless
Cover plates :	304 stainless
Brazing material:	Copper
Connections:	304 stainless

The advantages of Brazed PHE :

- Compact structure and easy installation
 - Made of thin plates
 - High heat exchanging coefficient
 - Small liquid retardation
- Light in weight
 - 20%-30% of shell-tube heat exchanger
- Small consumption of water
 - only need 1/3 of shell-tube heat exchanger water.
- Durability
 - Withstand high temperature 400 C and high pressure 45 bar.
- Low scaling coefficient
 - High turbulence reduces scaling coefficient



Braze PHE dimensional data

Model	BL14	BL20	BL26	BL26C
Width A (mm)	78	78	111	124
Height B (mm)	206	310	310	304
Length E (mm)	9+2.3n	9+2.3n	10+2.36n	13+2.4n
Horizontal port distance C (mm)	42	42	50	70
Vertical port distance D (mm)	172	282	250	250
Max pressure [Mpa]	3	3	3/4.5	3
Max flowrate [M3/h]	3.6	3.6	8.1	8.1
Weight [kg]	0.6+0.06n	1.0+0.08n	1.3+0.12n	2.2+0.16n

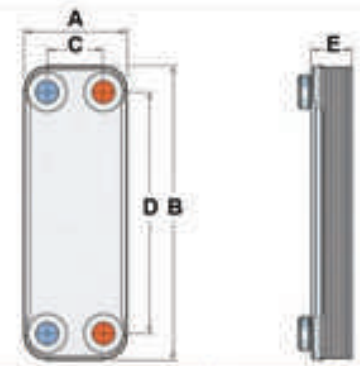

Model	BL50	BL95	BL120	BL190	BL200	BL600
Width A (mm)	111	191	246	307	321	429
Height B (mm)	525	616	528	696	738	1388
Length E (mm)	10+2.35n	11+2.35n	13+2.36n	13+2.75n	13+2.7n	22+2.78n
Horizontal port distance C (mm)	50	92	174	179	188	220
Vertical port distance D (mm)	466	519	456	567	603	1190
Max pressure [Mpa]	3/4.5	3/4.5	3	3	2.1	1.5
Max flowrate [M3/h]	12.7	39	42	100	100	300
Weight [kg]	2.6+0.19n	7.8+0.36n	7.2+0.52n	12.5+0.72n	13+0.75n	31.8+1.73n

Model	BL100 *	BL210 *
Width A (mm)	246	322
Height B (mm)	495	739
Length G (mm)	10+2.15n	13+2.55n
Up Horizontal port distance C (mm)	157	205.2
Low Horizontal port distance D (mm)	168	224
Gas Vertical port distance E (mm)	405	631
Water Vertical port distance F (mm)	408	568
Max pressure [Mpa]	3/4.5	3/4.5
Max flowrate [M3/h]	42	100
Weight [kg]	6.5+0.37n	13+0.78n

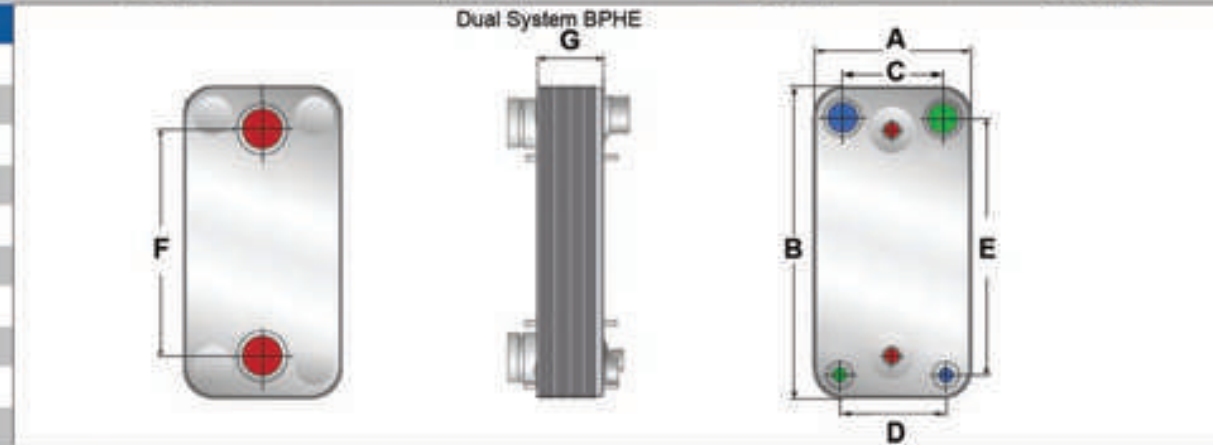

• BHPE Plates and Channel Types

BPHEs are available with different types of channel plates where the herringbone pattern varies. The chevrons can be obtuse (high theta plate, D) or acute (low theta plate, X).



• Connections:



*Thread NPT/ BSP standard are all available.
*More connections are available on request.

Baode Condenser Selection Form

Capacity (KW)	Tdew 35°C Water 25/30°C			Tdew 40°C Water 30/35°C			Tdew 50°C Water 40/45°C			Tdew 60°C Water 50/55°C			Water Flowrate M3/h
	Model			Model			Model			Model			
	BL26	BL50C	BL95B	BL26	BL50C	BL95B	BL26	BL50C	BL95B	BL26	BL50C	BL95B	
2.5	12			12			12			14			0.43
3.8	16			16			18			18			0.60
5.0	18			20			22			22			0.86
7.5	26			28			30			32			1.28
10.0	34			36			40			42			1.71
12.5	42	18		46	18		48	20		52	20		3.14
15.0	48	22		54	22		58	24		62	24		2.58
17.5	56	24		62	24		66	26		70	26		3.00
20.0	64	26		68	26		72	28		76	28		3.43
22.5		28		70	28		74	30		78	30		3.85
25.0		30		72	30		76	32		80	32		4.28
27.5		34		74	34		78	36		82	36		4.71
30.0		36		76	36		80	38		84	38		5.14
32.5		40		78	40		82	42		86	42		5.57
35.0		42		80	42		84	44		88	44		6.01
37.5		46		82	46		86	48		90	48		6.42
40.0		48		84	48		88	50		92	50		6.85
42.5		50		86	50		90	54		94	54		7.28
45.0		52		88	52		92	56		96	56		7.71
47.5		56	36	90	56	36	94	60	38	98	60	38	8.14
50.0		58	38	92	58	38	96	64	40	100	64	40	8.56
62.5			46		48			52			56		10.70
75.0			54		56			60			66		12.86
87.5			62		64			70			76		15.00
100.0			70		74			80			88		17.13
125.0			88		92			100			108		21.41
150.0			104		108			118			128		25.69
175.0			120		126			138			150		29.97
200.0			138		144			156					34.25

Baode Evaporator Selection Form

Capacity (KW)	Tdew 2°C Water 12/7°C			Tdew 3°C Water 12/7°C			Tdew 5°C Water 15/10°C			Tdew 10°C Water 20/15°C			Water Flowrate M3/h
	Model			Model			Model			Model			
	BL26	BL50D	BL95A	BL26	BL50D	BL95A	BL26	BL50D	BL95A	BL26	BL50D	BL95A	
2.5	16			18			14			14			0.43
3.8	20			22			18			18			0.60
5.0	24			28			24			24			0.86
7.5	34			40			34			32			1.28
10.0	44			52	26		42			40			1.71
12.5	54	26		64	30		52	26		50	24		3.14
15.0	64	30			36		62	30		58	28		2.58
17.5		34			40			34			32		3.00
20.0		38			46			38			36		3.43
22.5		42			50			42			38		3.85
25.0		46			56			44			42		4.28
27.5		50			60	36		50			46		4.71
30.0		56	34		66	38		52	34		50	30	5.14
32.5		60	36			42		58	36		54	32	5.57
35.0		64	40			44		62	38		58	36	6.01
37.5			42			48			40		62	38	6.42
40.0			44			50			44			40	6.85
42.5			46			54			46			42	7.28
45.0			48			56			48			44	7.71
47.5			52			60			50			46	8.14
50.0			54			62			54			48	8.56
62.5			66			78			64			60	10.70
75.0			80			94			76			72	12.86
87.5			94			110			88			82	15.00
100.0			108			124			100			96	17.13
125.0			134			158			126			118	21.41
150.0			162			194			154			144	25.69
175.0			190						184			170	29.97
200.0			220						214			198	34.25

Baode Air Dryer Data

Model	Size (mm)					Weight (kg)
	A	B	C	D	E	
BL14	172	42	78	206	9+2.3N	0.7+0.06n
BL26	250	50	111	310	10+2.36N	1.3+0.12n
BL95	519	92	191	616	11+2.72N	7.8+0.44n
BL200	603	188	321	738	13+2.7N	13+0.75n

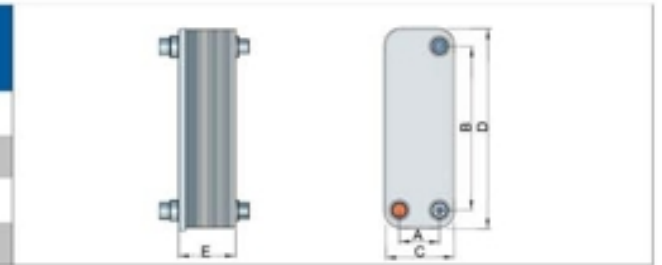

Flow rate (n.m ³ /min)	Model	Plates No	Gas side Connection	Air side Connection
0.62	BL14-17	17	3/8", 3/8"	1/2"
0.92	BL14-25	25	3/8", 1/2"	5/8"
1.2	BL14-33	33	3/8", 1/2"	5/8"
1.6	BL14-45	45	3/8", 1/2"	5/8"
1.85	BL26-26	26	1/2", 5/8"	1 1/8"
2.45	BL26-34	34	1/2", 5/8"	1 1/8"
3	BL26-42	42	1/2", 5/8"	1 1/8"
3.55	BL26-50	50	1/2", 5/8"	1 1/8"
4.1	BL26-58	58	1/2", 5/8"	1 1/8"
4.7	BL26-70	70	1/2", 5/8"	1 3/8"
5.4	BL26-81	81	1/2", 5/8"	1 3/8"
6.7	BL26-133	113	1/2", 5/8"	1 3/8"
7.1	BL95-26	26	1/2", 1 3/8"	2 1/2"
8.3	BL95-34	34	1/2", 1 3/8"	2 1/2"

Flow rate (n.m ³ /min)	Model	Plates No	Gas side Connection	Air side Connection
11.7	BL95-46	46	1/2", 1 3/8"	2 1/2"
14.2	BL95-58	58	1/2", 1 3/8"	2 1/2"
16.7	BL95-70	70	1/2", 1 3/8"	2 1/2"
20	BL95-86	86	1/2", 1 3/8"	2 1/2"
23	BL95-102	102	1/2", 1 3/8"	2 1/2"
40	BL200-80	80	1 3/8", 2"	3"
45	BL200-92	92	1 3/8", 2"	3"
50	BL200-108	108	1 3/8", 2"	3"
55	BL200-124	124	1 3/8", 2"	3"
60	BL200-148	148	1 3/8", 2"	3"
65	BL200-172	172	1 3/8", 2"	3"
70	BL200-196	196	1 3/8", 2"	3"
75	2*BL200-72	2*72	1 3/8", 2"	3"
80	2*BL200-80	2*80	1 3/8", 2"	3"

Model	BL14	BL26	BL95	BL200
Min Temp	-160°C	-160°C	-160°C	-160°C
Max Temp	225°C	225°C	225°C	225°C
Design Pressure	30 bar	30 bar	30 bar	16 bar
Test Pressure	45 bar	45 bar	45 bar	21 bar

● The Principle of Baode Air dryer.

There are 2 steps for the air dryers.

- By the evaporator cooling, the refrigerated air dryers separate humidity from compressed air. This cooling effect comes from the evaporation of the refrigerant. As the air cools, it loses its ability to hold moisture. Then use the separator to collect the condensate.
- A heat recovery air to air heat exchanger that reheats the air to ambient temperature in the air dryer for optimal efficiency.

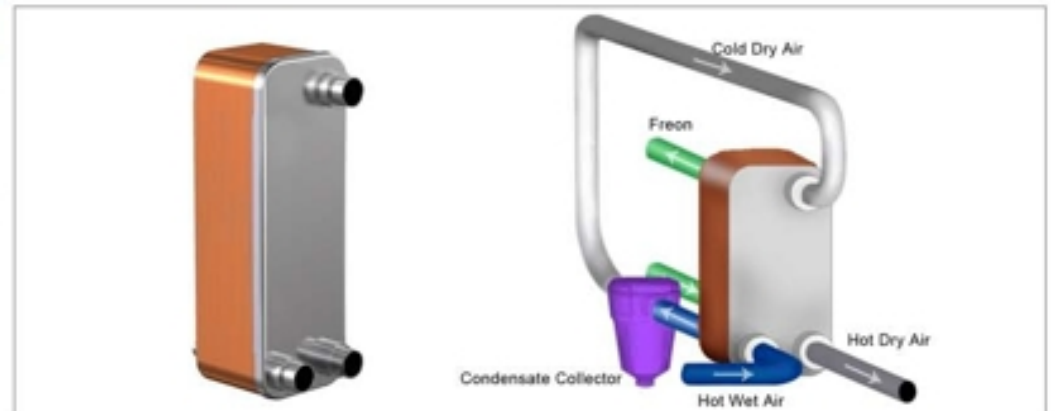

Hydraulic Oil Coolers Quick Select Form

Power Capacity		Model	Connection Description		ISO VG68 Oil				Water				Dry Weight	
Btu/hr	KW		Oil Inlet / Outlet (D1,D2)	Water Inlet / Outlet (D3,D4)	Flowrate		Pressure Drop		Flow Rate		Pressure Drop		lbs	Kgs
					GPM	Liter/m	Psi	Kpa	GPM	Liter/m	Psi	Kpa		
15,000	4.40	BL14- 14D	3/4" Male Thread	3/4" Male Thread	8	30.32	7.5	52	4	15.16	1.7	12	3	1.36
25,000	7.33	BL14- 20D	3/4" Male Thread	3/4" Male Thread	14	53.06	11.3	78	7	26.53	2.4	17	3.7	1.68
34,000	9.96	BL14- 28D	3/4" Male Thread	3/4" Male Thread	18	68.22	10.3	71	9	34.11	2.1	14	4.5	2.04
25,000	7.33	BL26- 10D	1" Male Thread	1" Male Thread	8	30.32	13.5	93	4	15.16	3.4	23	5.5	2.49
44,000	12.90	BL26- 18D	1" Male Thread	1" Male Thread	12	45.48	10.3	71	6	22.74	1.9	13	7.8	3.54
56,000	16.41	BL26- 24D	1" Male Thread	1" Male Thread	14	53.06	8.7	60	7	26.53	1.4	10	9.5	4.31
82,000	24.03	BL26- 34D	1" Male Thread	1" Male Thread	20	75.8	8.9	61	10	37.9	1.4	10	12.4	5.62
108,000	31.65	BL26- 44D	1" Male Thread	1" Male Thread	26	98.54	9.2	63	13	49.27	1.4	10	15.3	6.94
125,000	36.63	BL26- 50D	1" Male Thread	1" Male Thread	30	113.7	9.5	65	15	56.85	1.5	10	17	7.71
150,000	43.96	BL26- 60D	1" Male Thread	1" Male Thread	36	136.44	9.8	68	18	68.22	1.6	11	19.9	9.03
172,000	50.41	BL26- 70D	1" Male Thread	1" Male Thread	40	151.6	9	62	20	75.8	1.5	10	22.7	10.30
237,000	69.46	BL26- 100D	1" Male Thread	1" Male Thread	54	204.66	10.1	70	27	102.33	1.8	12	31.3	14.20
160,000	46.89	BL95- 20D	2" Male Thread	2" Male Thread	22	83.38	8.9	61	11	41.69	1.2	8	34.8	15.79
262,000	76.78	BL95- 30D	2" Male Thread	2" Male Thread	36	136.44	9.9	68	18	68.22	1.3	9	44.5	20.19
363,000	106.38	BL95- 40D	2" Male Thread	2" Male Thread	50	189.5	10.5	72	25	94.75	1.4	10	54.2	24.59
452,000	132.47	BL95- 50D	2" Male Thread	2" Male Thread	60	227.4	10	69	30	113.7	1.3	9	63.9	28.99
570,000	167.05	BL95- 60D	2" Male Thread	2" Male Thread	80	303.2	11.7	81	40	151.6	1.6	11	73.6	33.38
670,000	196.36	BL95- 70D	2" Male Thread	2" Male Thread	94	356.26	11.9	82	47	178.13	1.6	11	83.3	37.78
748,000	219.22	BL95- 80D	2" Male Thread	2" Male Thread	100	379	10.9	75	50	189.5	1.4	10	93	42.18
836,000	245.01	BL95- 90D	2" Male Thread	2" Male Thread	110	416.9	10.7	74	55	208.45	1.4	10	102.7	46.58
925,000	271.09	BL95- 100D	2" Male Thread	2" Male Thread	120	454.8	10.6	73	60	227.4	1.4	10	112.4	50.98

Oil to Water flow rate 2:1, oil outlet temp. 120°F (50 °C), Water inlet temp. 80°F (27 °C) .

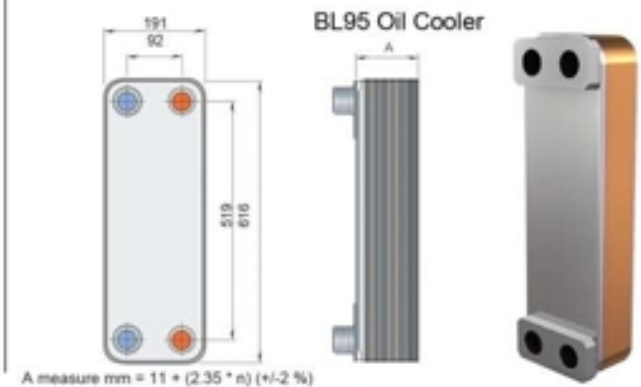
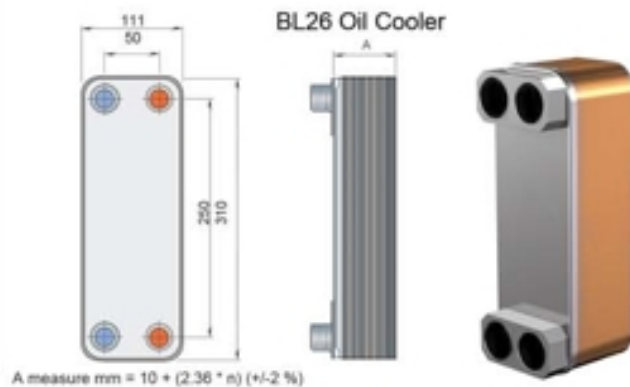
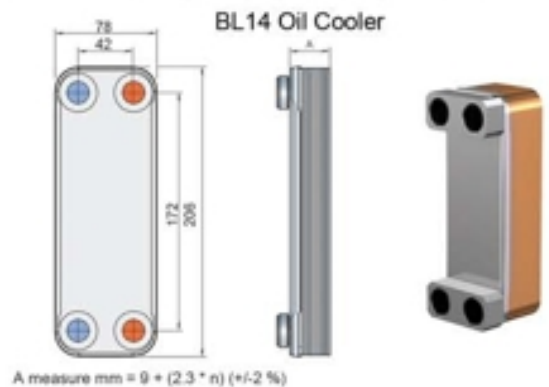

Gasket Plate Heat Exchanger

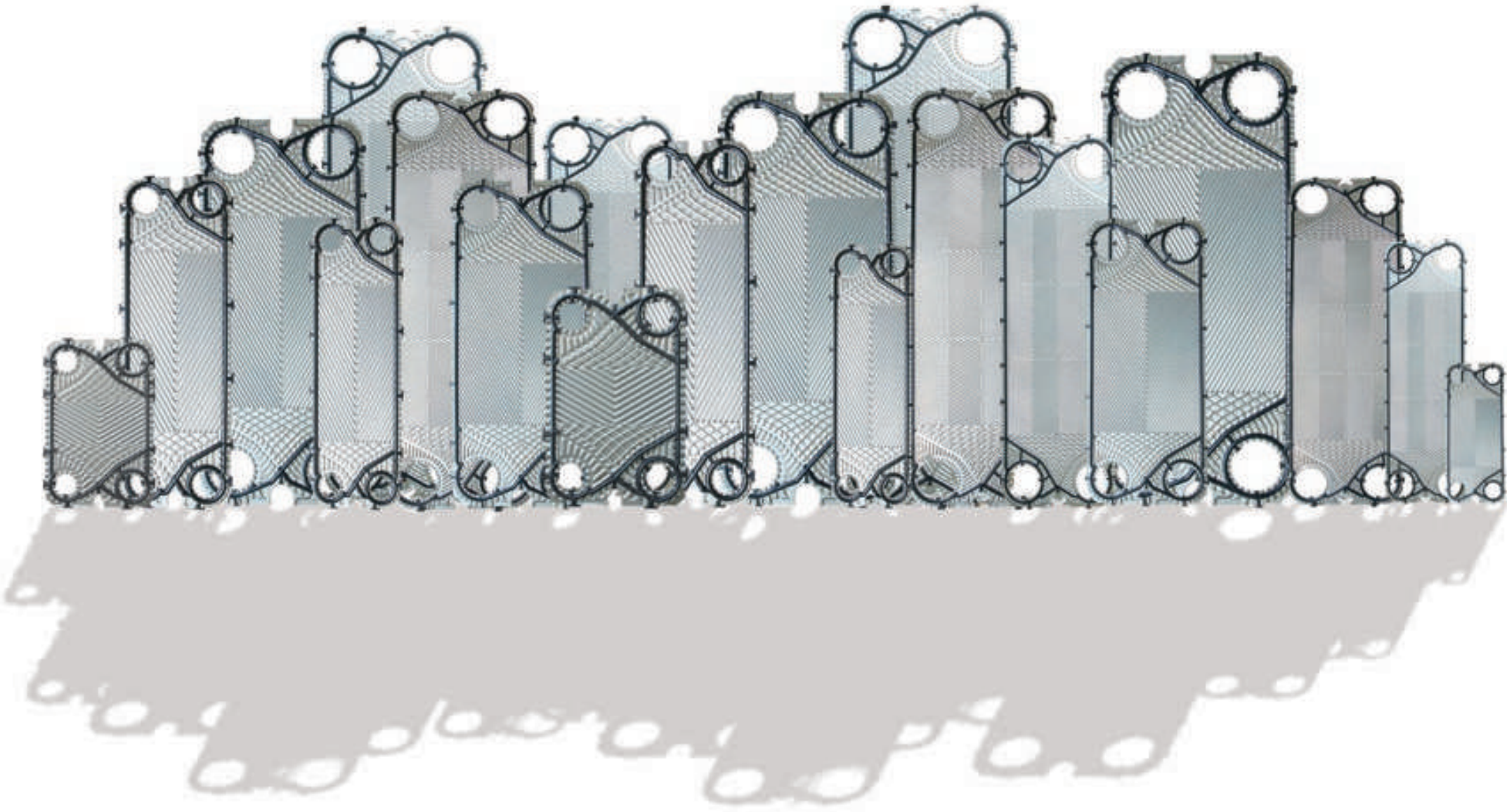

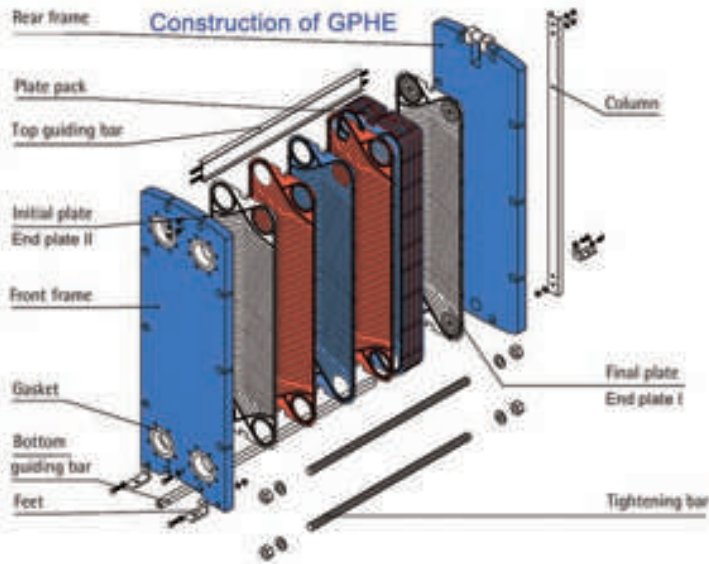
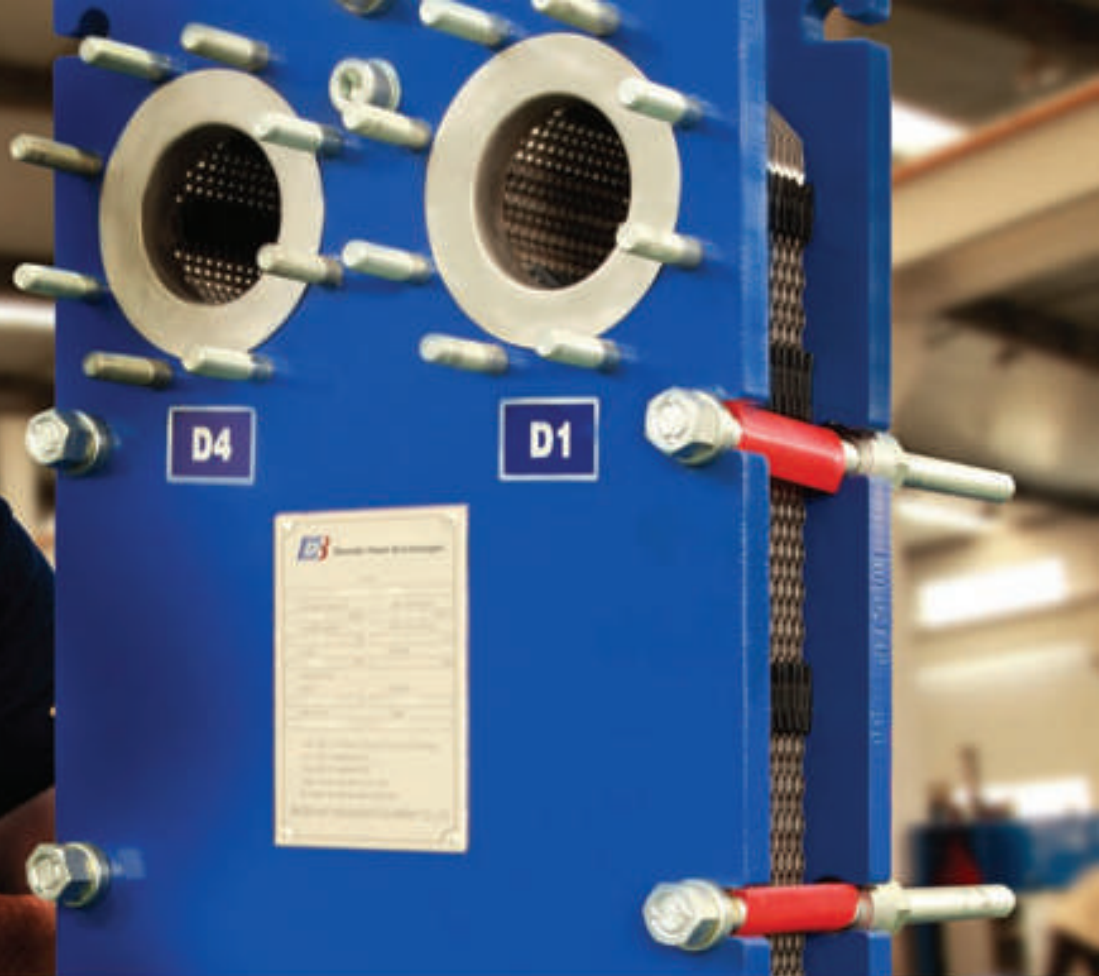

Connections available:



Specification of Gasket PHE	
Frame Material:	Carbon Steel / Stainless
Plate Material:	304/ 316L Stainless, Ti, SMO, Hastelloy
Thickness:	0.5 / 0.6 mm
Gasket Material:	NBR, EPDM, Viton
Max Pressure:	10 or 16 bar

Advantages of the Baode Gasket Plate Heat Exchanger

- Less space & more efficient**
 Gasket plate heat exchanger is compact size! With the compact designs they just need 22–50% less space in the system than a comparable shell & tube heat exchanger. so they require up to 75% less cooling media, you just need a smaller pumps that will consume less energy.
- Easy maintenance**
 When cleaning is needed, gasket plate heat exchanger can easily be opened, giving access to the plate surfaces, use pressure water or certain liquid to clean.

Gasket Plate Heat Exchanger data sheet

Model	BH30	BH60B / BH60H		LB100B	SH60H	SH200B
Height, H [mm]	480	920	940	1885	704	1405
Width, W [mm]	180	320	330	480	400	740
Min standard length, L [mm]	400	500	500	850	530	900
Max standard length, L [mm]	650	1500	1500	2350	1430	2700
Vertical port distance, VC [mm]	357	640	640	1338	380	698
Horizontal port distance, HC [mm]	60	140	140	225	203	363
Max temperature [°C]	180	180	180	180	180	180
Max pressure [barg]	16	10	16	10	16	10/16
Flange size	Pipe 1 1/4"	DN50/2"	DN50/2"	DN100/4"	DN65/2"	DN200/8"
Max. flow rate [kg/s]	4	16		50	20	190

Model	BH100B / BH100H		BH150B / BH150H		BH200H	BH250
Height, H [mm]	1084	1084	1885	1885	2150	2695
Width, W [mm]	470	470	610	650	750	920
Min standard length, L [mm]	700	700	1150	1150	1250	1550
Max standard length, L [mm]	2300	2300	2050	3250	3350	3350
Vertical port distance, VC [mm]	719	719	1294	1294	1478	1939
Horizontal port distance, HC [mm]	225	225	298	298	353	439
Max temperature [°C]	180	180	180	180	180	180
Max pressure [barg]	10	16	10	16	10/16	10/16
Flange size	DN100/4"	DN100/4"	DN150/6"	DN150/6"	DN200/8"	DN200/DN250/8"/10"
Max. flow rate [kg/s]	50		80		225	250

Model	BH300H
Height, H [mm]	2920
Width, W [mm]	1190
Min standard length, L [mm]	1650
Max standard length, L [mm]	5200
Vertical port distance, VC [mm]	1842
Horizontal port distance, HC [mm]	596
Max temperature	180
Max pressure [barg]	10/16
Flange size	DN300/DN350/12"/14"
Max. flow rate [kg/s]	497

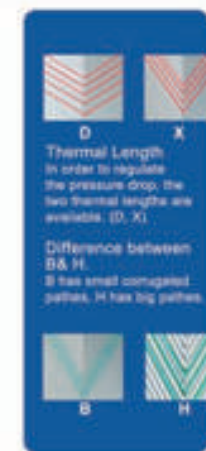
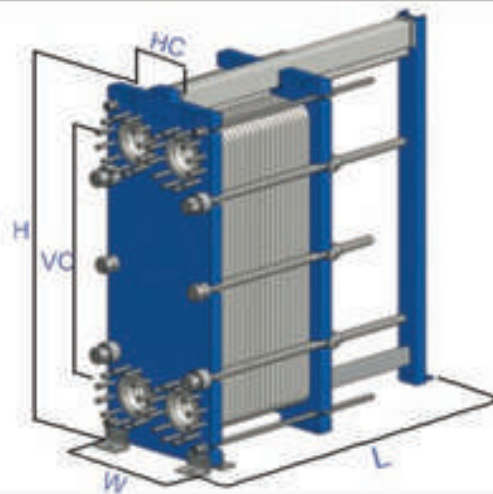

Baode Model code explanation

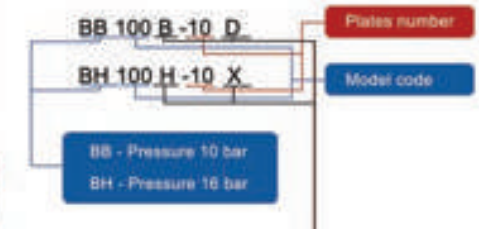

D
Thermal Length
In order to regulate
the pressure drop, the
two thermal lengths are
available. (D, X)

B **H**
Difference between
BA H
B has small corrugated
pattern, H has big pattern.

B **H**

Material Selection Form



Water/Water

The largest part of our production of heat exchangers is used for water/water duties, i.e. water heated or cooled with water. This can be achieved by different methods:

Water must be cooled:

Here, water with a lower temperature is used, for example from a cooling tower, lake, river or sea.

Water must be heated:

Here, water with a higher temperature is used, for example district heating, boiler or hot process water.

Some typical uses of plate heat exchangers

- District heating
- Tap water heating
- Swimming pool heating
- Heat recovery (engine cooling)
- Temperature control of fish farms
- Steel industry – furnace cooling
- Power industry – central cooling
- Chemical – industry – process cooling

Material Select form				
Chloride Content	Max Temperature			
	80 °C	80 °C	100 °C	120 °C
10 ppm	304	304	304	316
25 ppm	304	304	316	316
50 ppm	316	316	316	Ti
80 ppm	316	316	316	Ti
150 ppm	316	Ti	Ti	Ti
300 ppm	Ti	Ti	Ti	Ti
> 300 ppm	Ti	Ti	Ti	Ti
Gasket Material	NBR			
	EPDM			

Water/Oil

In some industries, oil has to be cooled using water. There are below main oils:

- Mineral oil
- Synthetic oil
- Hydraulic oils
- Lubricating oils
- Motor oils
- Oils used within manufacturing industries

Some typical uses of plate heat exchangers

- Hydraulic oil cooling
- Quench oil cooling
- Cooling of motor oil in engine test beds.

Material Select form				
Chloride Content	Max Temperature			
	80 °C	80 °C	100 °C	120 °C
10 ppm	304	304	304	316
25 ppm	304	304	316	316
50 ppm	316	316	316	Ti
80 ppm	316	316	316	Ti
150 ppm	316	Ti	Ti	Ti
300 ppm	Ti	Ti	Ti	Ti
> 300 ppm	Ti	Ti	Ti	Ti
Gasket Material	NBR			
	EPDM			

Water/Glycol

When there is a risk of freezing, add glycol to the water.

Glycol has a different heat capacity from water and therefore needs a somewhat larger heat transfer area to perform the same duty. On the other hand, the physical properties of the various glycols are much the same.

Examples of glycols are:

- Ethylene glycol (mono, di or tri)
- Propylene glycol.

Some typical uses of plate heat exchangers

- As an intercooler in a heat pump
- Chilled water production in food factories
- Cooling of air conditioning circuits
- Solar heating systems

Material Select form				
Chloride Content	Max Temperature			
	80 °C	80 °C	100 °C	120 °C
10 ppm	304	304	304	316
25 ppm	304	304	316	316
50 ppm	316	316	316	Ti
80 ppm	316	316	316	Ti
150 ppm	316	Ti	Ti	Ti
300 ppm	Ti	Ti	Ti	Ti
> 300 ppm	Ti	Ti	Ti	Ti
Gasket Material	NBR			
	EPDM			



GPHE for Heating

Radiator Heating GPHE Quick Selection

Temp. in -out/out-in	160 -80/90-70	135 -70/70-55	35 -80/95-70	135 -80/95-70	135 -80/90-70	135 -80/90-70	130 -80/95-70
Max P.D prim/sec	50/20 kPa	20/20 kPa	10/20 kPa	20/30 kPa	10/20 kPa	20/30 kPa	10/20 kPa
Capacity, kW	Model	Model	Model	Model	Model	Model	Model
50	BB30B-18D	BB30B-14H	BB30B-18D	BB30B-18D	BB30B-18D	BB30B-14D	BB30B-20D
100	BB30B-34D	BB30B-30H	BB30B-30D	BB30B-30D	BB30B-34D	BB30B-24D	BB30B-34D
150	BH60H-12H	BH60H-12X	BB30B-42D	BB30B-42D	BB30B-54D	BB30B-42D	BB30B-48D
200	BH60H-16H	BH60H-16X	BB30B-58H	BB30B-56D	BH60H-16H	BB30B-60D	BB30B-62D
300	BH60H-24H	BH60H-22X	BH60H-24H	BH60H-24H	BH60H-24H	BH60H-20H	BH60H-28H
400	BH60H-34H	BH60H-32X	BH60H-32H	BH60H-32H	BH60H-34H	BH60H-28H	BH60H-34H
500	BH60H-44H	BH100H-22H	BH60H-38H	BH60H-38H	BH60H-44H	BH60H-34H	BH60H-42H
750	BH100H-40H	BH100H-34H	BH100H-34D	BH60H-54H	BH100H-42D	BH100H-34D	BH100H-36D
1,000	BH100H-52H	BH100H-46H	BH100H-46D	BH100H-42D	BH100H-58D	BH100H-46D	BH100H-48D

Temp. in -out/out-in	130 -80/95-70	130 -80/9-70	30 -80/90-70	135 -75/95-70	135 -75/90-70	130 -70/85-65	10 -70/90-65
Max P.D prim/sec	20/30 kPa	10/20 kPa	20/30 kPa	50/20 kPa	50/20 kPa	50/20 kPa	30/30 kPa
Capacity, kW	Model	Model	Model	Model	Model	Model	Model
50	BB30B-20D	BB30B-18D	BB30B-16D	BB30B-32D	BB30B-24D	BB30B-26D	BB30B-28D
100	BB30B-34D	BB30B-34D	BB30B-28D	BB30B-60D	BB30B-44D	BB30B-46D	BB30B-52D
150	BB30B-48D	BB30B-54D	BB30B-42D	BH60H-18D	BB30B-64D	BB30B-66D	BH60H-24H
200	BB30B-62D	BH60H-16H	BB30B-60D	BH60H-22D	BH60H-26H	BH60H-28H	BH60H-30H
300	BH60H-28H	BH60H-24H	BH60H-20H	BH60H-34D	BH60H-38H	BH60H-40H	BH60H-42H
400	BH60H-34H	BH60H-34H	BH60H-26H	BH60H-46D	BH60H-48H	BH60H-50H	BH100B-26D
500	BH60H-42H	BH60H-44H	BH60H-34H	BH60H-58D	BH100H-34D	BH100H-36D	BH100B-32D
750	BH100H-36D	BH100H-42D	BH100H-34D	BH100H-68D	BH100H-50D	BH100H-52D	BH100B-50D
1,000	BH100H-48D	BH100H-58D	BH100H-46D	BH100H-88D	BH100H-64D	BH100H-68D	BH100B-66D

Temp. in -out/out-in	110 -60/80-55	110 -60/70-50	105 -70/85-65	95 -45/75-40	75 -40/70-35	65 -40/60-35	60 -50/45-35
Max P.D prim/sec	30/30 kPa	30/30 kPa	50/30 kPa	20/20 kPa	10/20 kPa	10/30 kPa	20/20 kPa
Capacity, kW	Model	Model	Model	Model	Model	Model	Model
50	BB30B-48D	BB30B-18D	BB30B-52D	BH60B-12D	BH60B-46D	BH60B-30D	BB30B-24D
100	BB30B-90D	BB30B-30D	BH60H-16D	BH60B-20D	BH60B-84D	BH60B-54D	BH60H-14X
150	BH60H-20H	BB30B-44D	BH60H-22D	BH60B-28D	BH60B-124D	BH60B-80D	BH60H-18X
200	BH60H-26H	BB30B-62D	BH60H-28D	BH60B-34D	BH60B-162D	BH60B-104D	BH60H-24X
300	BH60H-36H	BH60H-24H	BH60H-40D	BH60B-50D	BH100B-294D	BH60B-152D	BH100H-22H
400	BH60H-46D	BH60H-32D	BH60H-50D	BH60B-64D	BH100B-390D	BH100B-208D	BH100H-28H
500	BH60H-56D	BH60H-38D	BH100B-64D	BH60B-78D	-	BH100B-258D	BH100H-36H
750	BH60H-62D	BH100H-36D	BH100B-86D	BH60B-114D	-	BH100B-382D	BH100H-54H
1,000	BH100B-68D	BH100H-48D	BH100B-134D	BH100B-132D	-	-	-

Tap Water Heating GPHE Quick selection

Temp. in -out/out-in	90 -70/60-10	90 -70/55-10	90 -70/55-10	90 -70/50-10	90 -60/60-30	80 -60/55-10	80 -50/60-10
Max P.D prim/sec	20/20 kPa	20/30 kPa	30/30 kPa	30/30 kPa	30/30 kPa	30/30 kPa	20/20 kPa
Capacity, kW	Model	Model	Model	Model	Model	Model	Model
50	BB30B-14H	BB30B-14H	BB30B-12H	BB30B-12H	BB30B-12D	BB30B-14H	BB30B-14H
100	BB30B-24H	BB30B-24H	BB30B-20H	BB30B-20H	BB30B-20D	BB30B-24H	BB30B-24H
150	BB30B-36H	BB30B-36H	BB30B-28H	BB30B-28H	BB30B-30D	BB30B-32H	BB30B-36H
200	BH60H-14X	BH60H-14X	BB30B-40H	BB30B-40H	BB30B-40D	BB30B-42H	BB30B-50H
300	BH60H-18X	BH60H-18X	BH60H-16X	BH60H-16X	BB30B-62D	BH60H-20X	BH60H-20H
400	BH60H-24X	BH60H-24X	BH60H-20X	BH60H-20X	BH60H-20H	BH60H-23X	BH60H-26H
500	BH60H-30X	BH60H-30X	BH60H-24X	BH60H-24X	BH60H-24H	BH60H-30X	BH60H-30H
750	BH100H-26H	BH100H-22X	BH100H-22H	BH100H-18X	BH60H-36H	BH100H-24H	BH60H-46H
1,000	BH100H-36H	BH100H-28X	BH100H-30H	BH100H-24X	BH60H-50H	BH100H-30H	BH100H-40D

Temp. in -out/out-in	70 -50/60-10	70 -50/55-10	70 -40/55-5	70 -35/60-10	70 -35/55-10	70 -35/55-5	70 -35/55-5
Max P.D prim/sec	20/20 kPa	20/30 kPa	30/30 kPa	20/20 kPa	30/30 kPa	20/20 kPa	30/30 kPa
Capacity, kW	Model	Model	Model	Model	Model	Model	Model
50	BB30B-22D	BB30B-20D	BB30B-22D	BB30B-34D	BB30B-34D	BB30B-30D	BB30B-30D
100	BB30B-38D	BB30B-36D	BB30B-40D	BB30B-62D	BB30B-62D	BB30B-54D	BB30B-54D
150	BB30B-56D	BB30B-56D	BB30B-56D	BB30B-90D	BB30B-90D	BB30B-78D	BB30B-74D
200	BH60H-22H	BH60H-18H	BB30B-76D	BH60H-18D	BH60H-18D	BH60H-18D	BH60H-18D
300	BH60H-30H	BH60H-26H	BH60B-22H	BH60H-26D	BH60H-26D	BH60H-26D	BH60H-22D
400	BH60H-40H	BH60H-36H	BH60B-28H	BH60H-34D	BH60H-32D	BH60H-34D	BH60H-28D
500	BH60H-48H	BH60H-46H	BH60B-36H	BH60H-42D	BH60H-40D	BH60H-42D	BH60H-36D
750	BH100H-44D	BH100H-44D	BH60B-54H	BH60H-66D	BH60H-56D	BH60H-66D	BH60H-52D
1,000	BH100H-60D	BH100H-60D	BH60B-76H	BH60H-92D	BH60H-74D	BH60H-92D	BH60H-72D

Temp. in -out/out-in	70 -30/60-5	70 -25/60-10	65 -20/55-10	60 -30/55-25	60 -25/55-5	60 -25/55-5	6 -20/55-10
Max P.D prim/sec	50/50 kPa	20/20 kPa	20/25 kPa	30/30 kPa	20/20 kPa	30/30 kPa	20/25 kPa
Capacity, kW	Model	Model	Model	Model	Model	Model	Model
50	BH60B-10D	BH60B-14D	BH60B-18D	BH60B-42D	BH60B-14D	BH60B-14D	BH60B-32D
100	BH60B-14D	BH60B-20D	BH60B-32D	BH60B-78D	BH60B-24D	BH60B-24D	BH60B-58D
150	BH60B-16D	BH60B-28D	BH60B-44D	BH60B-114D	BH60B-34D	BH60B-34D	BH60B-84D
200	BH60B-20D	BH60B-36D	BH60B-56D	BH60B-150D	BH60B-42D	BH60B-42D	BH60B-110D
300	BH60B-28D	BH60B-52D	BH60B-82D	BH100B-268D	BH60B-60D	BH60B-60D	BH60B-164D
400	BH60B-36D	BH60B-66D	BH60B-108D	BH100B-354D	BH60B-78D	BH60B-78D	BH100B-256D
500	BH60B-44D	BH60B-82D	BH60B-132D	BH100B-440D	BH60B-96D	BH60B-96D	BH100B-320D
750	BH60B-64D	BH60B-120D	BH60B-196D	-	BH100B-136D	BH100B-136D	-
1,000	BH60B-82D	BH100B-148D	BH100B-274D	-	BH100B-178D	BH100B-178D	-



Contact details:

PT. Metalindo Prima Engineering

Office :
Jl. K.H. Zainal Mustafa No. 17 - Jakarta Timur (13350)
Phone : 62 21 856 1234 - Fax : 62 21 851 3109
Web : www.metalindoengineering.com
Email : info@metalindoengineering.com

